

### 订货方法(HOW TO ORDER):

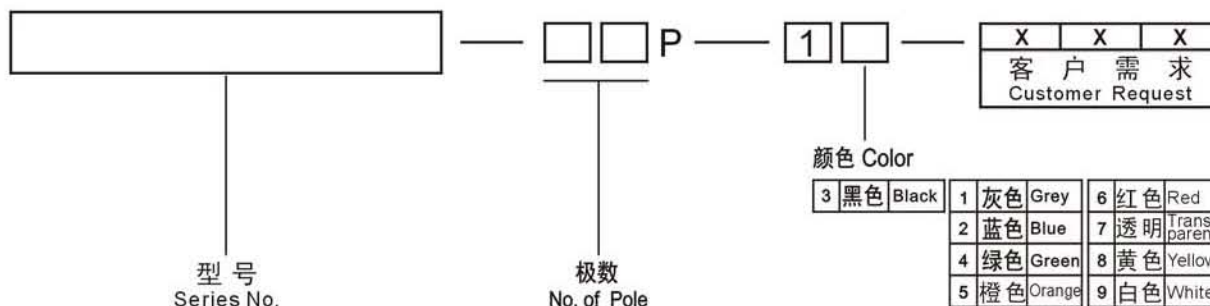

### 规格(SPECIFICATION)

材质		Materials	
塑件:	PC, UL94V-2	Housing:	PC,UL94V-2
端子:	合金,镀金	Terminal:	Alloy,Tin-Plated
螺丝:	M5/M7,钢,镀金	Screw:	M5/M7,Gold-Plated
性能		Capability	
额定电压/电流:	300V / 30A	Rated:	300V / 30A
使用温度:	-40°C~+80°C	Temp.Range:	-40°C~+80°C
耐电压:	AC2000V / 1Min	Withstand Voltage:	AC2000V / 1Min
绝缘阻抗:	1000MΩ / DC500V	Insulation Resistance:	1000MΩ / DC500V
适用线径:	18-12AWG	Wire Range:	18-12AWG
最大锁紧扭力:	2.0N.m 17.5Lb.in	Max.Torque Value:	2.0N.m 17.5Lb.in

## EA27-1

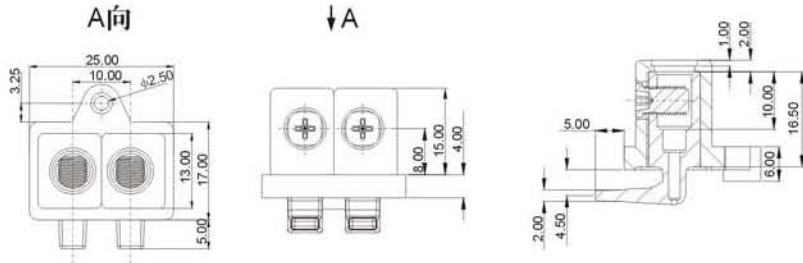

螺丝: M5  
Screw: M5

额定电压/电流: 300V / 30A  
Rated: 300V / 30A

适用线径: 18-12AWG  
Wire Range: 18-12AWG

最大锁紧扭力: 2.0N.m 17.5Lb.in  
Max.Torque Value: 2.0N.m 17.5Lb.in

## EA27-2

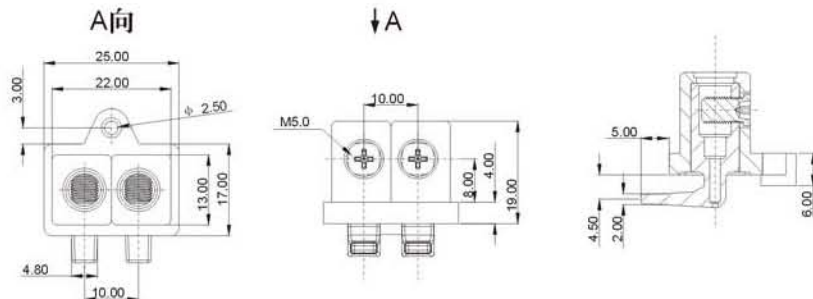

螺丝: M5  
Screw: M5

额定电压/电流: 300V / 30A  
Rated: 300V / 30A

适用线径: 18-12AWG  
Wire Range: 18-12AWG

最大锁紧扭力: 2.0N.m 17.5Lb.in  
Max.Torque Value: 2.0N.m 17.5Lb.in

## EA28-1

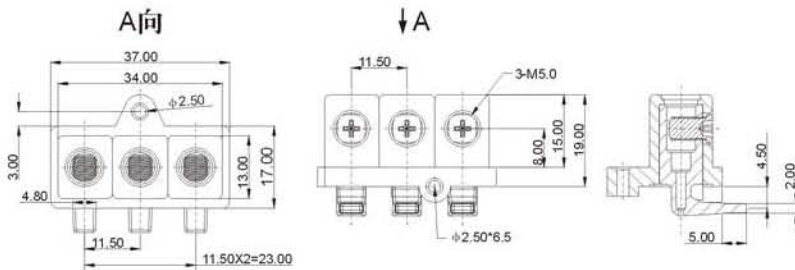

螺丝: M5  
Screw: M5

额定电压/电流: 300V / 30A  
Rated: 300V / 30A

适用线径: 18-12AWG  
Wire Range: 18-12AWG

最大锁紧扭力: 2.0N.m 17.5Lb.in  
Max.Torque Value: 2.0N.m 17.5Lb.in

## EA28-2

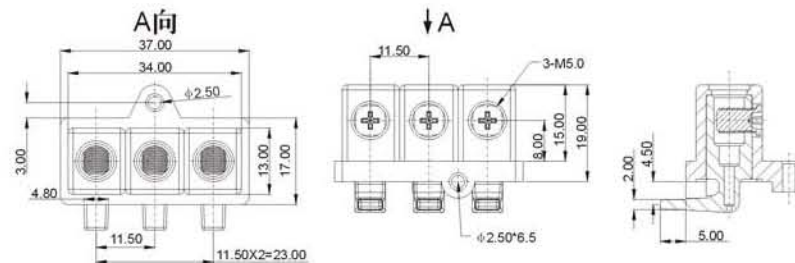

螺丝: M5  
Screw: M5

额定电压/电流: 300V / 30A  
Rated: 300V / 30A

适用线径: 18-12AWG  
Wire Range: 18-12AWG

最大锁紧扭力: 2.0N.m 17.5Lb.in  
Max.Torque Value: 2.0N.m 17.5Lb.in

## EA29-1

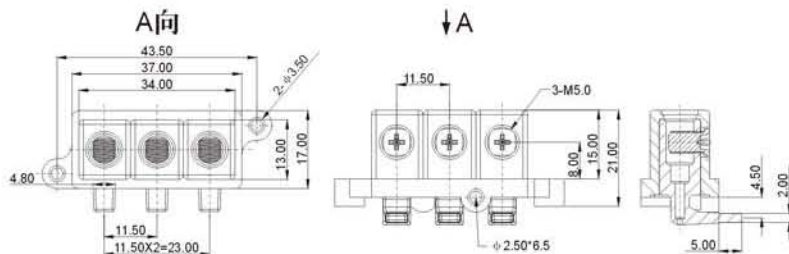

螺丝: M5  
Screw: M5

额定电压/电流: 300V / 30A  
Rated: 300V / 30A

适用线径: 18-12AWG  
Wire Range: 18-12AWG

最大锁紧扭力: 2.0N.m 17.5Lb.in  
Max. Torque Value: 2.0N.m 17.5Lb.in

## EA29-2

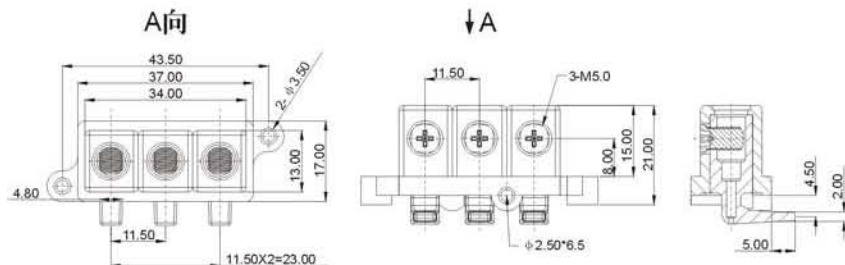

螺丝: M5  
Screw: M5

额定电压/电流: 300V / 30A  
Rated: 300V / 30A

适用线径: 18-12AWG  
Wire Range: 18-12AWG

最大锁紧扭力: 2.0N.m 17.5Lb.in  
Max. Torque Value: 2.0N.m 17.5Lb.in

## EA30-1

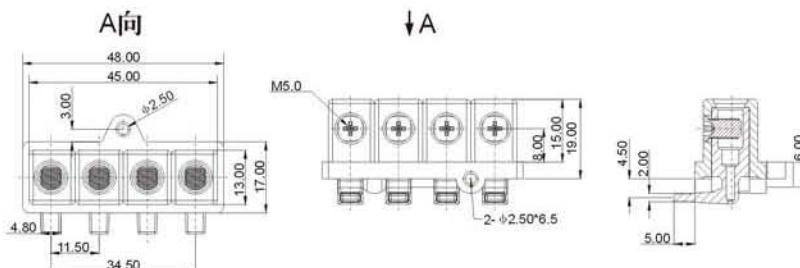

螺丝: M5  
Screw: M5

额定电压/电流: 300V / 30A  
Rated: 300V / 30A

适用线径: 18-12AWG  
Wire Range: 18-12AWG

最大锁紧扭力: 2.0N.m 17.5Lb.in  
Max. Torque Value: 2.0N.m 17.5Lb.in

## EA30-2

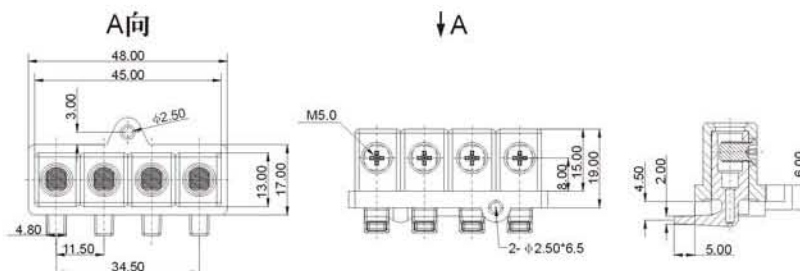

螺丝: M5  
Screw: M5

额定电压/电流: 300V / 30A  
Rated: 300V / 30A

适用线径: 18-12AWG  
Wire Range: 18-12AWG

最大锁紧扭力: 2.0N.m 17.5Lb.in  
Max. Torque Value: 2.0N.m 17.5Lb.in

## EA31-1

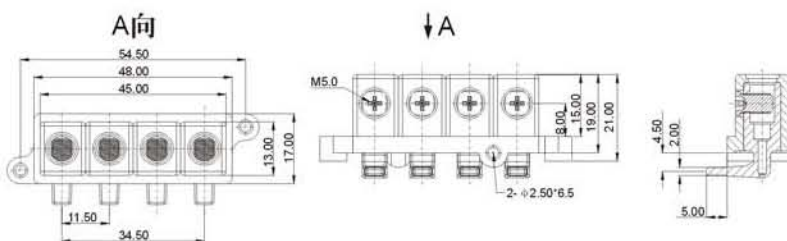

螺丝: M5  
Screw: M5

额定电压/电流: 300V / 30A  
Rated: 300V / 30A

适用线径: 18-12AWG  
Wire Range: 18-12AWG

最大锁紧扭力: 2.0N.m 17.5Lb.in  
Max. Torque Value: 2.0N.m 17.5Lb.in

## EA31-2

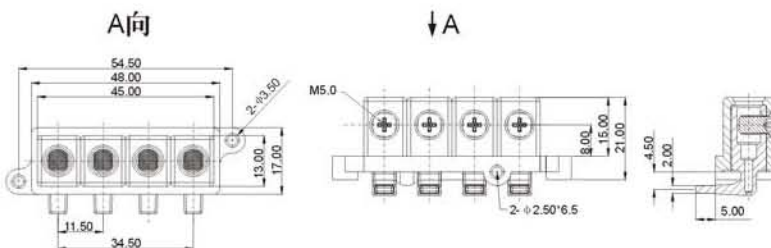

螺丝: M5  
Screw: M5

额定电压/电流: 300V / 30A  
Rated: 300V / 30A

适用线径: 18-12AWG  
Wire Range: 18-12AWG

最大锁紧扭力: 2.0N.m 17.5Lb.in  
Max. Torque Value: 2.0N.m 17.5Lb.in

## EA32-1

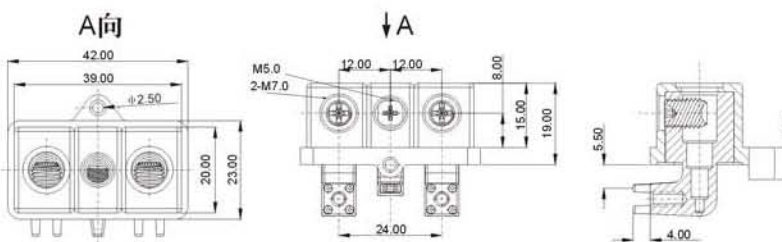

螺丝: M5 / M7  
Screw: M5 / M7

额定电压/电流: 300V / 30A  
Rated: 300V / 30A

适用线径: 18-12AWG  
Wire Range: 18-12AWG

最大锁紧扭力: 2.0N.m 17.5Lb.in  
Max. Torque Value: 2.0N.m 17.5Lb.in

## EA32-2

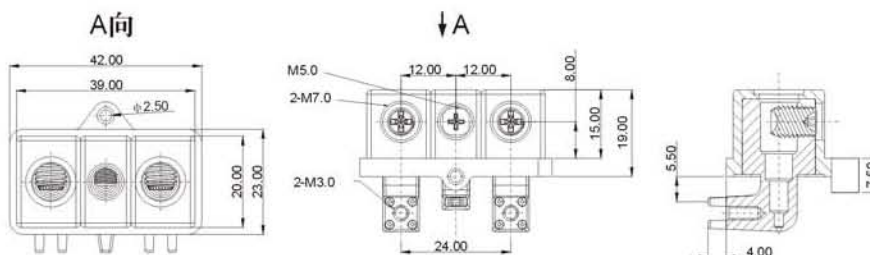

螺丝: M5 / M7  
Screw: M5 / M7

额定电压/电流: 300V / 30A  
Rated: 300V / 30A

适用线径: 18-12AWG  
Wire Range: 18-12AWG

最大锁紧扭力: 2.0N.m 17.5Lb.in  
Max. Torque Value: 2.0N.m 17.5Lb.in

## EA33-1

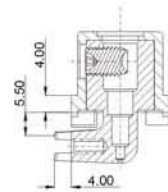
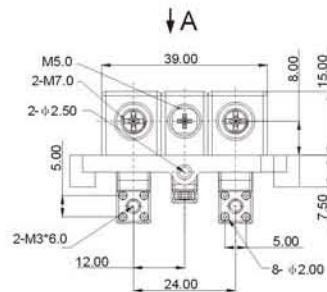
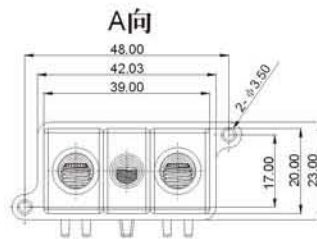

螺丝: M5 / M7  
Screw: M5 / M7

额定电压/电流: 300V / 30A  
Rated: 300V / 30A

适用线径: 18-12AWG  
Wire Range: 18-12AWG

最大锁紧扭力: 2.0N.m 17.5Lb.in  
Max. Torque Value: 2.0N.m 17.5Lb.in

## EA33-2

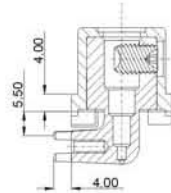
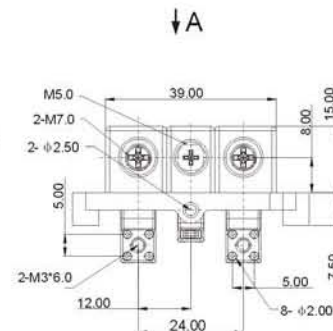
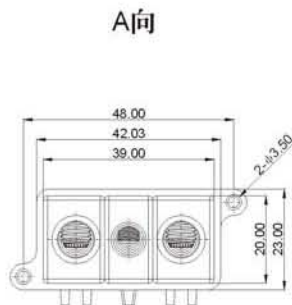

螺丝: M5 / M7  
Screw: M5 / M7

额定电压/电流: 300V / 30A  
Rated: 300V / 30A

适用线径: 18-12AWG  
Wire Range: 18-12AWG

最大锁紧扭力: 2.0N.m 17.5Lb.in  
Max. Torque Value: 2.0N.m 17.5Lb.in

## EA34-2

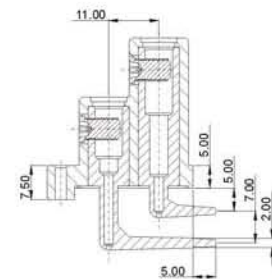
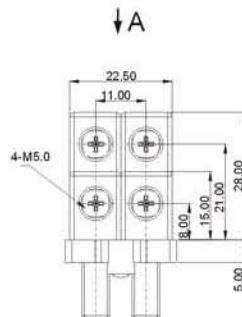
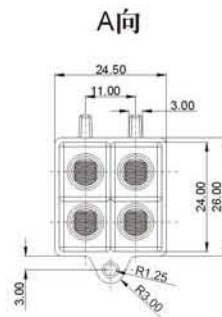

螺丝: M5  
Screw: M5

额定电压/电流: 500V / 40A  
Rated: 500V / 40A

适用线径: 18-10AWG  
Wire Range: 18-10AWG

最大锁紧扭力: 2.0N.m 17.5Lb.in  
Max. Torque Value: 2.0N.m 17.5Lb.in

## EA35-1



A向

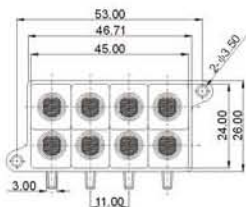

↓A

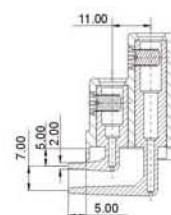
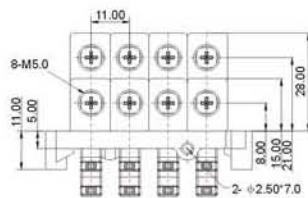

螺丝: M5  
Screw: M5

额定电压/电流: 500V / 40A  
Rated: 500V / 40A

适用线径: 18-10AWG  
Wire Range: 18-10AWG

最大锁紧扭力: 2.0N.m 17.5Lb.in  
Max. Torque Value: 2.0N.m 17.5Lb.in

## EA35-2



A向

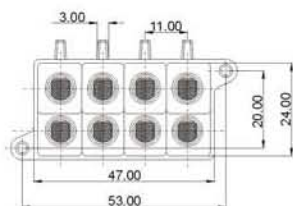

↓A

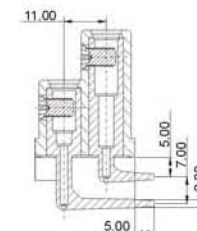
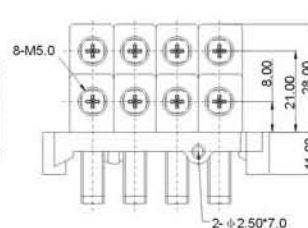

螺丝: M5  
Screw: M5

额定电压/电流: 500V / 40A  
Rated: 500V / 40A

适用线径: 18-10AWG  
Wire Range: 18-10AWG

最大锁紧扭力: 2.0N.m 17.5Lb.in  
Max. Torque Value: 2.0N.m 17.5Lb.in

## EA36-1



A向

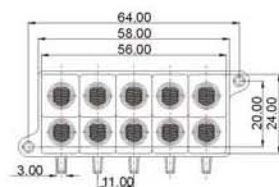

↓A

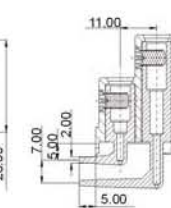
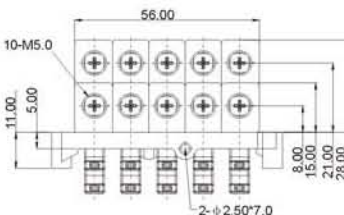

螺丝: M5  
Screw: M5

额定电压/电流: 500V / 40A  
Rated: 500V / 40A

适用线径: 18-10AWG  
Wire Range: 18-10AWG

最大锁紧扭力: 2.0N.m 17.5Lb.in  
Max. Torque Value: 2.0N.m 17.5Lb.in

## EA36-2

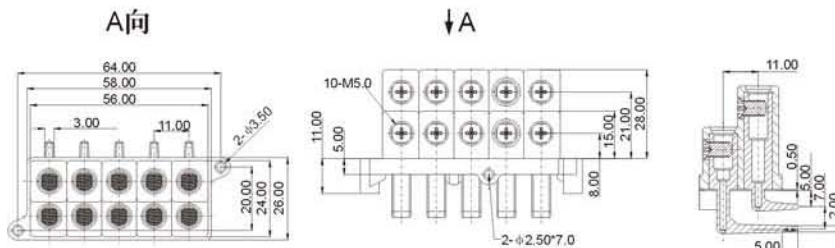

螺丝: M5  
Screw: M5

额定电压/电流: 500V / 40A  
Rated: 500V / 40A

适用线径: 18-10AWG  
Wire Range: 18-10AWG

最大锁紧扭力: 2.0N.m 17.5Lb.in  
Max. Torque Value: 2.0N.m 17.5Lb.in

## EA37-1

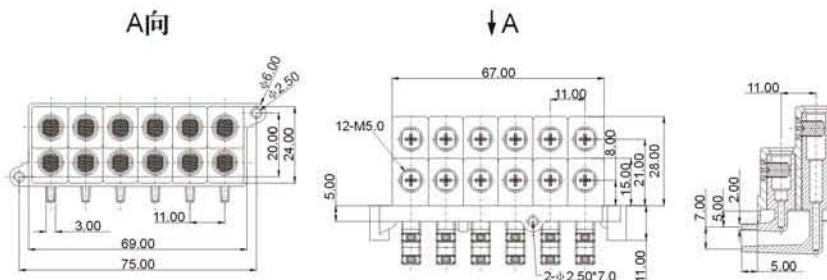

螺丝: M5  
Screw: M5

额定电压/电流: 500V / 40A  
Rated: 500V / 40A

适用线径: 18-10AWG  
Wire Range: 18-10AWG

最大锁紧扭力: 2.0N.m 17.5Lb.in  
Max. Torque Value: 2.0N.m 17.5Lb.in

## EA37-2

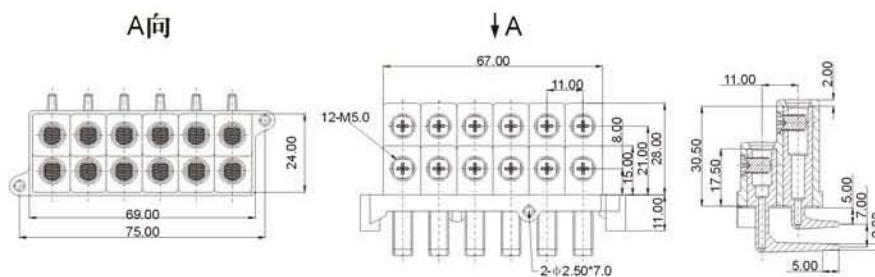

螺丝: M5  
Screw: M5

额定电压/电流: 500V / 40A  
Rated: 500V / 40A

适用线径: 18-10AWG  
Wire Range: 18-10AWG

最大锁紧扭力: 2.0N.m 17.5Lb.in  
Max. Torque Value: 2.0N.m 17.5Lb.in

# EA14

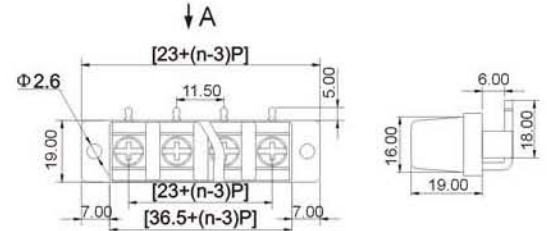
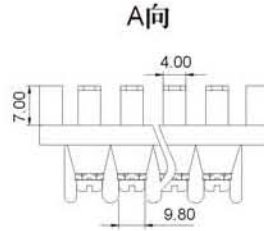

极数Poles: n=3,4,7,8

螺丝: M4  
Screw: M4

额定电压/电流: 300V / 30A  
Rated: 300V / 30A

适用线径: 22-12AWG  
Wire Range: 22-12AWG

最大锁紧扭力: 1.2N.m 10.6Lb.in  
Max. Torque Value: 1.2N.m 10.6Lb.in

# EA15

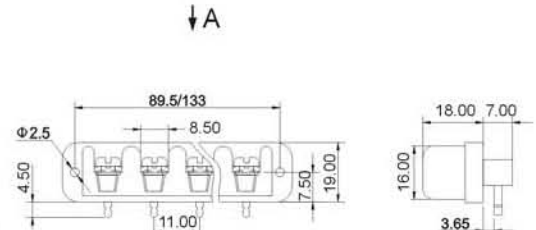
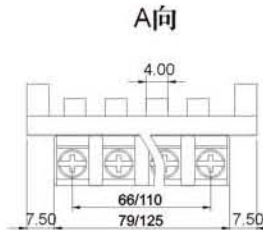

极数Poles: 7,11

螺丝: M4  
Screw: M4

额定电压/电流: 300V / 30A  
Rated: 300V / 30A

适用线径: 22-12AWG  
Wire Range: 22-12AWG

最大锁紧扭力: 1.2N.m 10.6Lb.in  
Max. Torque Value: 1.2N.m 10.6Lb.in

# EA16

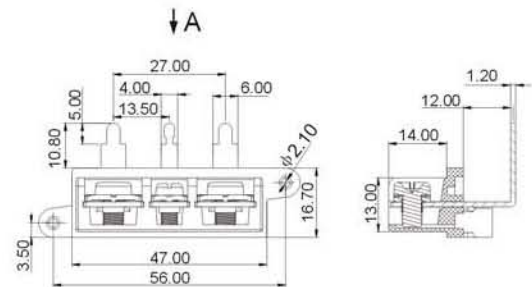
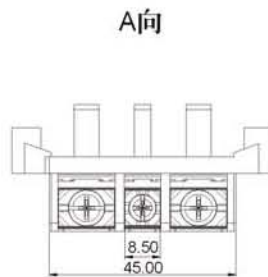

螺丝: M4  
Screw: M4

额定电压/电流: 300V / 30A  
Rated: 300V / 30A

适用线径: 22-12AWG  
Wire Range: 22-12AWG

最大锁紧扭力: 1.2N.m 10.6Lb.in  
Max. Torque Value: 1.2N.m 10.6Lb.in



## EA17

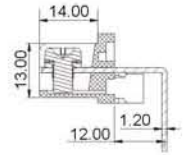
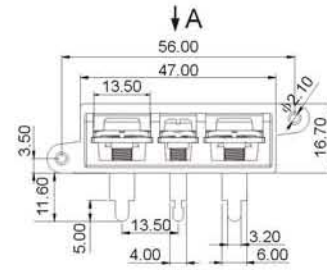
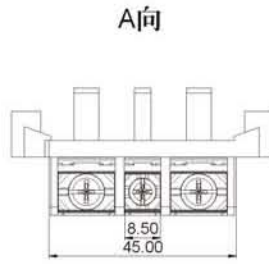

螺丝: M4  
Screw: M4

额定电压/电流: 300V / 30A  
Rated: 300V / 30A

适用线径: 22-12AWG  
Wire Range: 22-12AWG

最大锁紧扭力: 1.2N.m 10.6Lb.in  
Max. Torque Value: 1.2N.m 10.6Lb.in

## EA18-1

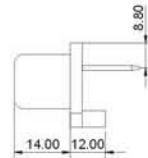
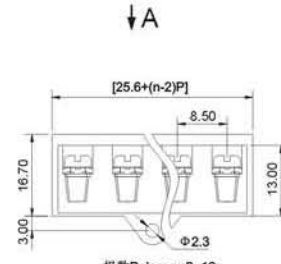
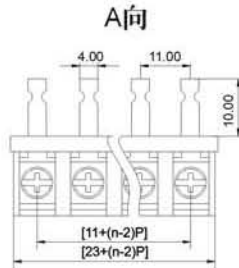

极数Poles: n=2-12

螺丝: M4  
Screw: M4

额定电压/电流: 300V / 30A  
Rated: 300V / 30A

适用线径: 18-10AWG  
Wire Range: 18-10AWG

最大锁紧扭力: 1.2N.m 10.6Lb.in  
Max. Torque Value: 1.2N.m 10.6Lb.in

## EA18-2

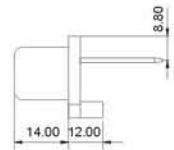
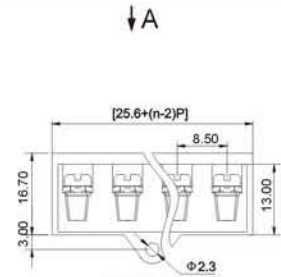
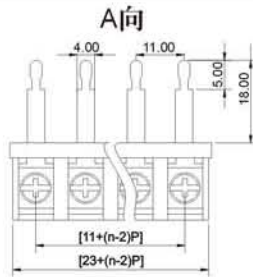

极数Poles: n=2-12

螺丝: M4  
Screw: M4

额定电压/电流: 300V / 30A  
Rated: 300V / 30A

适用线径: 18-10AWG  
Wire Range: 18-10AWG

最大锁紧扭力: 1.2N.m 10.6Lb.in  
Max. Torque Value: 1.2N.m 10.6Lb.in

## EA20

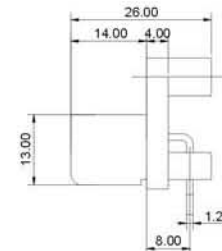
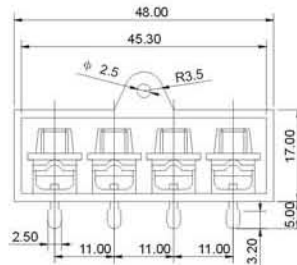
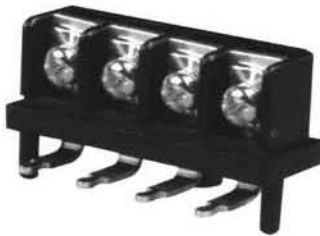

螺丝: M4  
Screw: M4

额定电压/电流: 300V / 30A  
Rated: 300V / 30A

适用线径: 22-12AWG  
Wire Range: 22-12AWG

最大锁紧扭力: 1.2N.m 10.6Lb.in  
Max. Torque Value: 1.2N.m 10.6Lb.in



K1 Tin-Plated

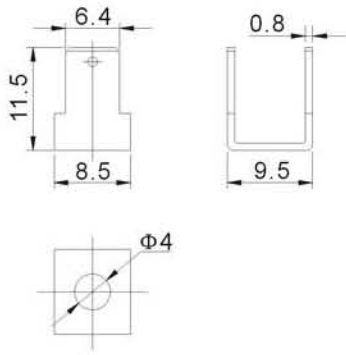

K5 Tin-Plated

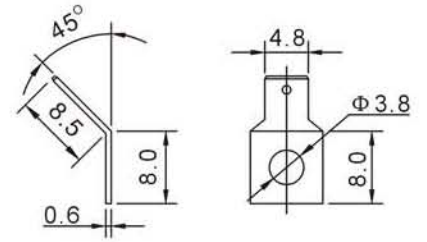

K2 Tin-Plated

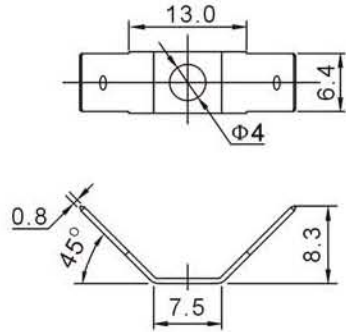

K6 Tin-Plated

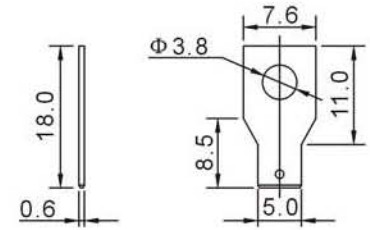

K3 Tin-Plated

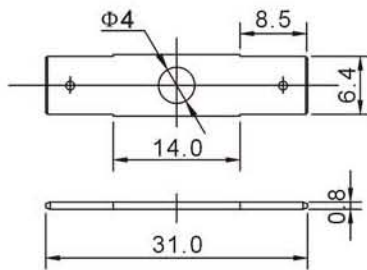

K7 Tin-Plated

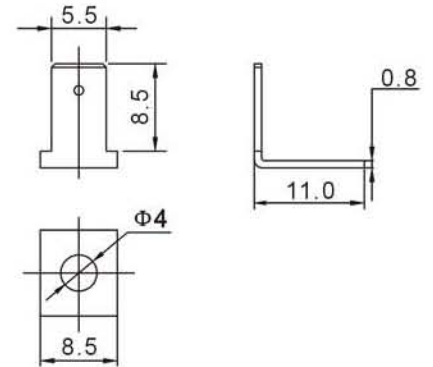

K4 Tin-Plated

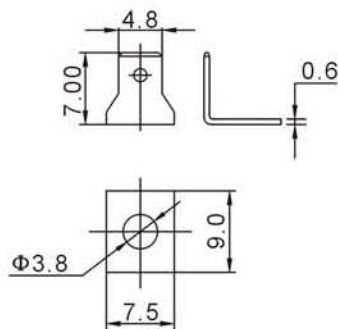

K8 Tin-Plated

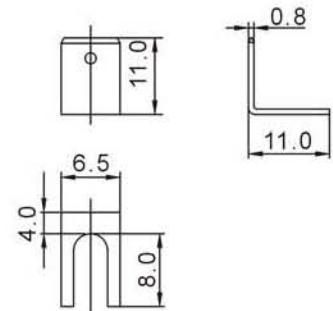



K9 Tin-Plated

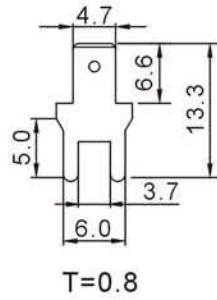

Rating:15A  
Screw:M4\*9  
Terminal:Tin-Plated  
Brass

K13 Tin-Plated

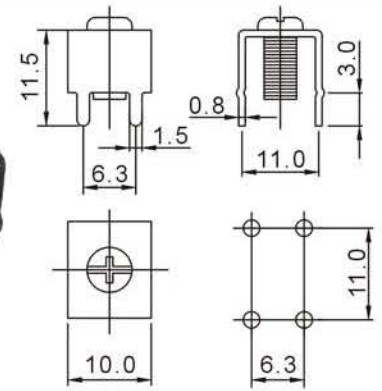

K10 Tin-Plated

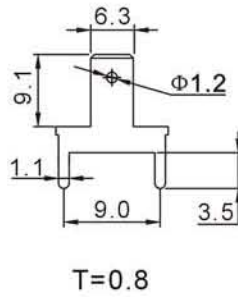

Rating:15A  
Screw:M3.5\*6  
Terminal:Tin-Plated  
Brass

K14 Tin-Plated

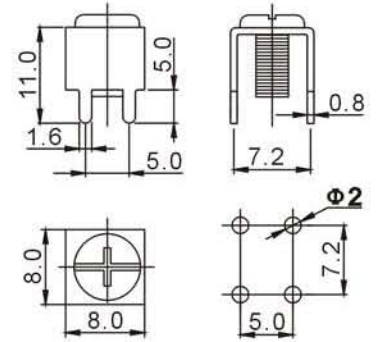

K11 Tin-Plated

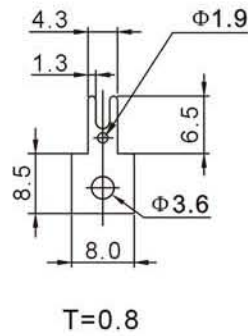

Rating:15A  
Screw:M3.5\*6  
Terminal:Tin-Plated  
Brass

K15 Tin-Plated

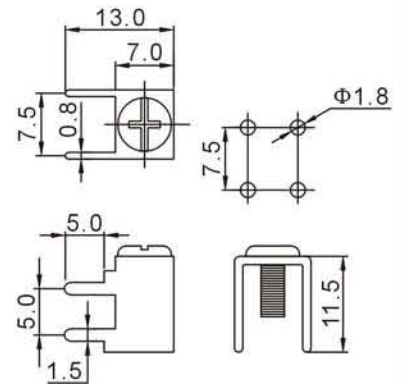

K12 Tin-Plated

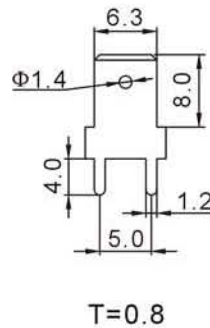

K16 Tin-Plated

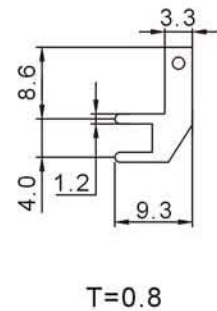



K17 Tin-Plated

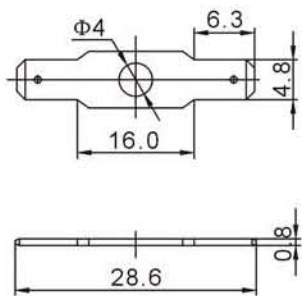

K21 Tin-Plated

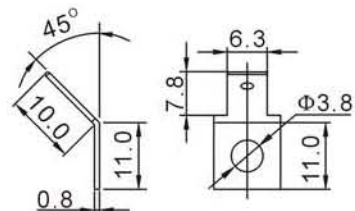

K18 Tin-Plated

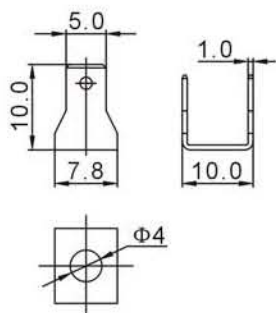

K22 Tin-Plated

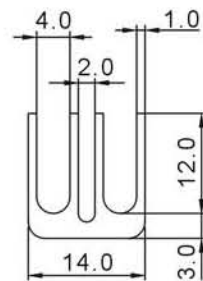

T=0.4



K19 Tin-Plated

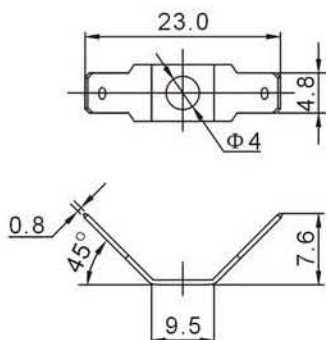

K23 Tin-Plated

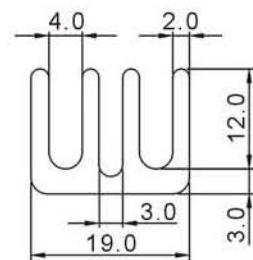

T=0.4



K20 Tin-Plated

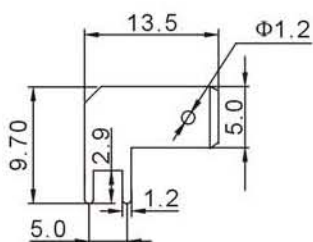

T=0.8



K24 Tin-Plated

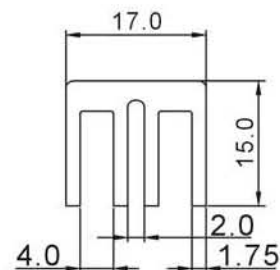

T=0.4